

1 {3D}

1. ONCE THIS DOCUMENT HAS BEEN SIGNED OFF, NO CHANGES WILL BE MADE TO THE DESIGN.
2. STAIRCASES DOES NOT INCLUDE ANY FINAL FINISHES OR BALLUSTRADING.
3. SCREEDING THICKNESS OF BOTH GROUND AND FIRST FLOOR TO BE CONFIRMED BY CONTRACTOR.
4. DESIGNPLUS WILL NOT BE RESPONSIBLE FOR ANY EXISTING FINISHES (I.E TILES, PAINT, CARPET etc.) DAMAGED DURING THE INSTALLATION OF ANY STAIRCASE.
5. ONCE FINAL MEASUREMENTS HAVE BEEN TAKEN ON SITE BY RHINO SLABS, ANY CHANGES DONE TO SITE AFTERWARDS WILL BE THE RESPONSIBILITY OF THE CLIENT OR THE CONTRACTOR TO NOTIFY DESIGNPLUS IMMEDIATELY.
6. SITE TO BE CLEARED AND PREPARED BY CONTRACTOR PRIOR TO INSTALLATION.
7. NO WALKING ON THE STAIRCASE IS ALLOWED PRIOR TO CASTING OF CONCRETE AND 3 DAYS AFTERWARDS.
8. ALL PROPS TO REMAIN FOR 14 DAYS AND WILL BE REMOVED BY DESIGNPLUS NOT BY THE CLIENT OR THEIR CONTRACTOR.
9. CLIENT OR CONTRACTOR TO CUT AND PREPAIR FOOTING UNLESS OTHERWISE QUOTED FOR.
10. ANY PERMANENT SUPPORT REQUIRED AFTER SITE AND STAIRCASE ASSESSMENT WILL BE QUOTED FOR.
10. SITE ACCESS OR DIFFICULTY OF ACCESS MIGHT INFLUENCE THE FINAL PRICE OF STAIRCASE.
11. ANY CUTTING OR REMOVING OF EXISTING SLAB WILL BE AT CLIENT'S COST.



1. ALL DIMENSIONS TO BE VERIFIED ON SITE BEFORE CONSTRUCTION
2. STAIRCASE MUST BE BUILT IN ACCORDANCE WITH THE NATIONAL BUILDING REGULATIONS (SANS 10400 PART M)
3. THIS DRAWING REMAINS THE PROPERTY OF DESIGNPLUS (PTY)LTD

CODE	SUITABILITY DESCRIPTION	
STATUS	PURPOSE OF ISSUE	
PROJECT		
U SHAPE STAIRCASE		
TITLE		
BLUE VALLEY		
CLIENT		
MASEDA		
DRAWN BY	CHECKED BY	DATE
S.VUMA	D.DUBE	2025/08/27
SCALE (@ A1)	PROJECT NUMBER	
	1	
DRAWING NUMBER	REV	
A100		

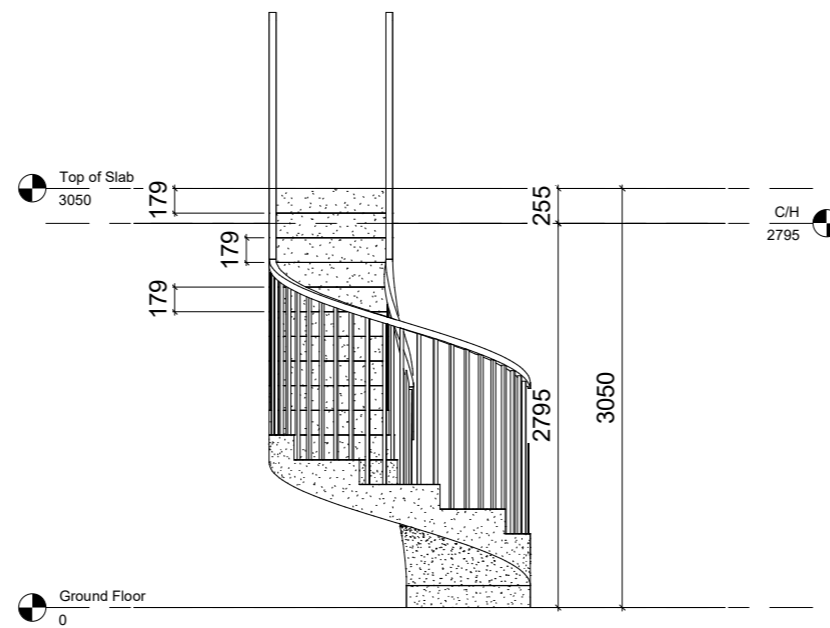
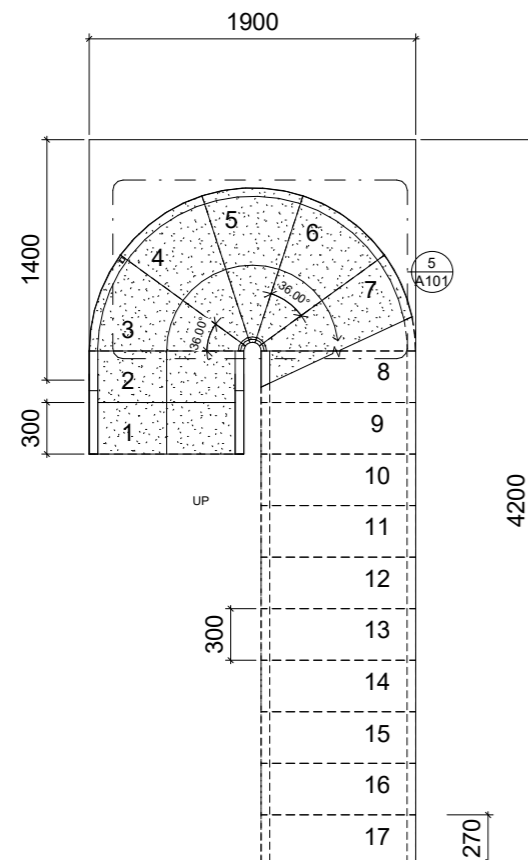

North
1 : 25

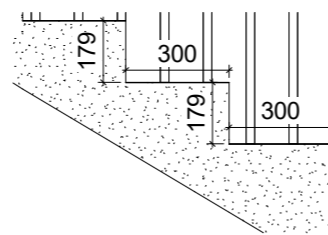

4 RISER DETAIL
1 : 10

Ground Floor
1 : 20

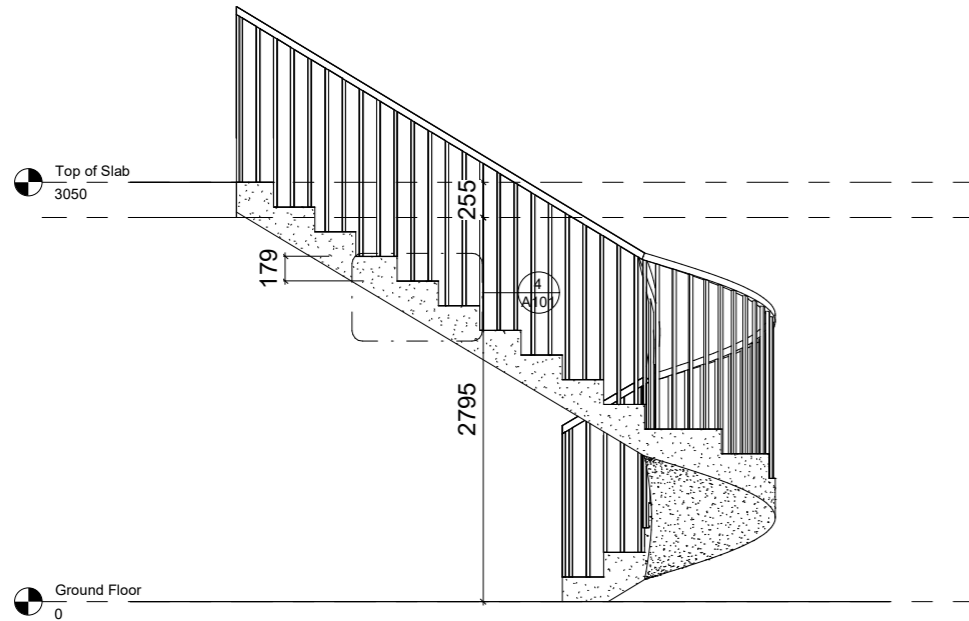

East
1 : 25

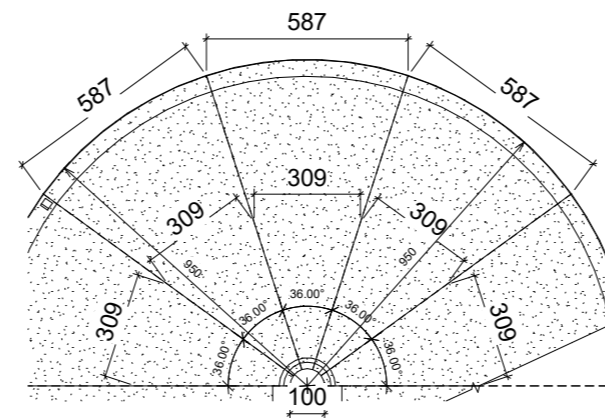

5 Ground Floor - Callout 1
1 : 10

1. ONCE THIS DOCUMENT HAS BEEN SIGNED OFF, NO CHANGES WILL BE MADE TO THE DESIGN.
2. STAIRCASES DOES NOT INCLUDE ANY FINAL FINISHES OR BALLUSTRADING.
3. SCREEDING THICKNESS OF BOTH GROUND AND FIRST FLOOR TO BE CONFIRMED BY CONTRACTOR.
4. DESIGNPLUS WILL NOT BE RESPONSIBLE FOR ANY EXISTING FINISHES (I.E TILES, PAINT, CARPET etc.) DAMAGED DURING THE INSTALLATION OF ANY STAIRCASE.
5. ONCE FINAL MEASUREMENTS HAVE BEEN TAKEN ON SITE BY RHINO SLABS, ANY CHANGES DONE TO SITE AFTERWARDS WILL BE THE RESPONSIBILITY OF THE CLIENT OR THE CONTRACTOR TO NOTIFY DESIGNPLUS IMMEDIATELY.
6. SITE TO BE CLEARED AND PREPARED BY CONTRACTOR PRIOR TO INSTALLATION.
7. NO WALKING ON THE STAIRCASE IS ALLOWED PRIOR TO CASTING OF CONCRETE AND 3 DAYS AFTERWARDS.
8. ALL PROPS TO REMAIN FOR 14 DAYS AND WILL BE REMOVED BY DESIGNPLUS NOT BY THE CLIENT OR THEIR CONTRACTOR.
9. CLIENT OR CONTRACTOR TO CUT AND PREPAIR FOOTING UNLESS OTHERWISE QUOTED FOR.
10. ANY PERMANENT SUPPORT REQUIRED AFTER SITE AND STAIRCASE ASSESSMENT WILL BE QUOTED FOR.
10. SITE ACCESS OR DIFFICULTY OF ACCESS MIGHT INFLUENCE THE FINAL PRICE OF STAIRCASE.
11. ANY CUTTING OR REMOVING OF EXISTING SLAB WILL BE AT CLIENT'S COST.



DESIGNPLUS (PTY)LTD

1. ALL DIMENSIONS TO BE VERIFIED ON SITE BEFORE CONSTRUCTION

2. STAIRCASE MUST BE BUILT IN ACCORDANCE WITH THE NATIONAL BUILDING REGULATIONS (SANS 10400 PART M)

3. THIS DRAWING REMAINS THE PROPERTY OF DESIGNPLUS (PTY)LTD

CODE	SUITABILITY DESCRIPTION
STATUS	PURPOSE OF ISSUE

PROJECT
U SHAPE STAIRCASE

TITLE
PLAN

CLIENT
MASEDA

DRAWN BY S.VUMA	CHECKED BY D.DUBE	DATE 08/27/25
SCALE (@ A1) As indicated	PROJECT NUMBER 1	
DRAWING NUMBER A101	REV	